

# Effective IM2 estimation for two-tone and WCDMA modulated blockers in zero-IF

Direct-conversion receiver architecture is currently the choice for the radio receiver section in 3G WCDMA handsets. It facilitates the complete integration of the radio section on chip, resulting in a lower cost and smaller radio. The IIP<sub>2</sub> requirements of a direct-conversion or zero-IF receiver, in the presence of uplink and downlink WCDMA modulated blockers, are presented.

By Walid Y. Ali-Ahmad

As third-generation (3G) wireless networks are currently expanding in Japan (IMT-2000), in Europe (UMTS) and in the United States (CDMA 2000), the need for low-cost, low power consumption, and low form factor user equipment (UE) is becoming important for the commercial development of 3G mobile handsets. The direct-conversion receiver architecture with the proper use of silicon process, circuit design techniques and architecture implementation represents a promising system solution for high integration platforms for 3G handsets. A fully integrated zero-IF receiver solution for 3G radios (Figure 1) is commercially available, and the receiver second-order input intercept point (IIP<sub>2</sub>) requirement is a key specification for the direct-conversion receiver solution.

As seen in Figure 1, direct-conversion or zero-IF receiver architecture enables the pathway for a full on-chip integration of the receiver as the signal is directly demodulated to baseband I and Q signals. In a 3G WCDMA full-duplex (FDD) operation mode, only an external duplexer is needed for separation between RX and TX sections. Furthermore, the post low-noise amplifier (LNA) RF filter is needed in a FDD radio to reject out-of-band blockers and transmitter leakage at demodulator input due to limited finite duplexer TX-RX isolation. In a zero-IF receiver IC, channel selectivity is achieved at baseband by on-chip low-pass filters. Following the channel filtering, I/Q signals at baseband are amplified by variable gain amplifiers (VGAs) before they get digitized in the analog baseband section of the radio modem IC. Design considerations for direct-conversion receivers have been studied thoroughly [1, 2].

## Second-order distortion effects

In a zero-IF receiver, second-order intermodulation products (IM2) have been shown to present a problematic source of

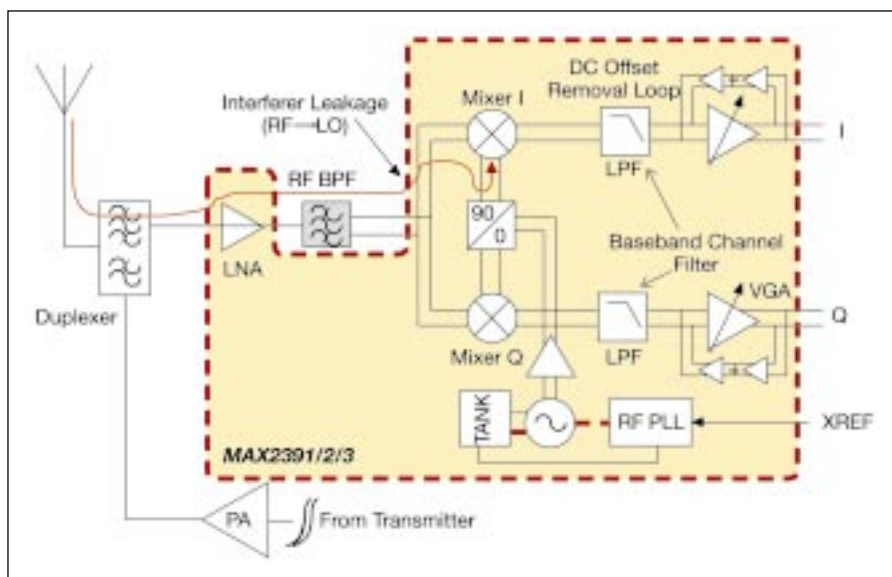

Figure 1. Direct-conversion receiver IC for 3GPP FDD handset radio.

interference [1], and care must be taken to minimize the level of these products in the receiver's baseband channel. In a zero-IF receiver, the front-end second-order non-linearity demodulates the AM components of an amplitude-modulated blocker down to baseband. Because these second-order IM2 products consist of the squared version of the blocker envelope, the bandwidth of these undesirable spectral components at baseband can be up to twice the bandwidth of the blocker's amplitude envelope. Depending on the desired signal modulation bandwidth at baseband, the IM2 products will contribute partially or fully to the degradation of the overall receiver's jamming margin.

The IM2 distortion products are those that occur in the downconverter section of a zero-IF receiver. This is due to the fact that the low-frequency IM2 products in the LNA are normally filtered out by AC coupling or bandpass filtering between the LNA and the

mixer blocks. Many mechanisms are responsible for the generation of IM2 products in a zero-IF receiver [3]. However, two main IM2 generation mechanisms are important:

■ *RF self-mixing*: It is due to the non-perfect hard-switching I-V characteristic of the commutating stage in a zero-IF receiver mixer and due to the RF signal leaking into the LO port because of parasitic coupling.

The non-perfect hard-switching happens in a mixer when it is driven with low LO powers, and hence, it behaves more like a linear multiplier. As a result, in the presence of an RF to LO leakage component at the LO port (Figure.1), the zero-IF mixer's output contains a signal that is proportional to both the square of the input signal and the RF-to-LO coupling factor. So second-order IM2 products are generated at baseband. This is detrimental to receiver performance when the RF signal leaking to the LO port is a strong blocker.

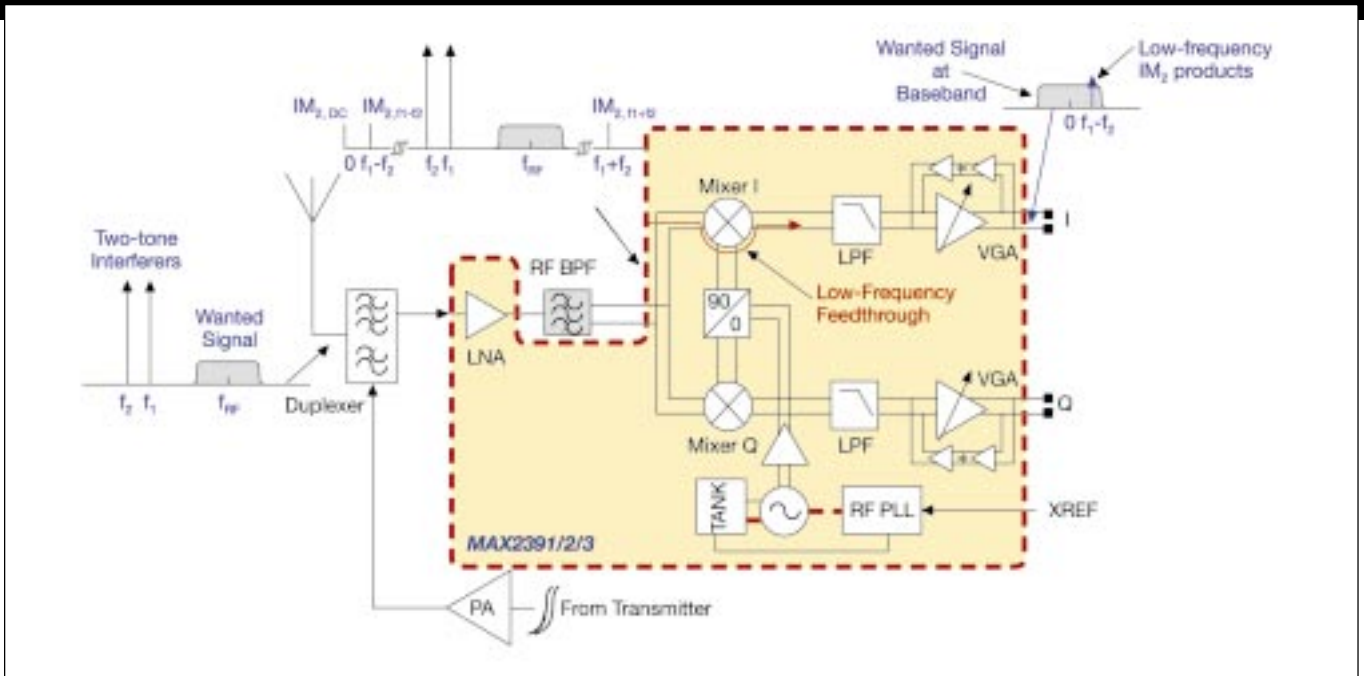

Figure 2. Second-order intermodulation distortion due to two-tone blocker in zero-IF receiver.

■ **Downconverter RF stage second-order non-linearity and LO stage switching-pairs mismatches:** On the introduction of a strong continuous wave (CW) or modulated blocker at the I/Q mixer's inputs in a zero-IF receiver, the second-order non-linearity in the active devices of the mixer transconductor or RF stage will generate low-frequency IM2 products. These products along with the desired RF signal and the blocker will be part of the transconductor stage output currents. In a perfectly balanced mixer with perfectly matched devices in the switching pairs or LO stage and perfectly matched mixer loads, the equivalent differential IM2 products are translated to high frequencies and the equivalent common-mode IM2 products are canceled out at the mixer differential output. However, in reality, the mismatches that exist in the LO stage devices in addition to the deviation of the LO duty cycle from 50% result in a direct low-frequency leakage gain that is presented to the low-frequency IM2 products. As a result, these products get translated to I/Q mixers baseband outputs

It is important to note that in the points discussed above, we assume that the downconverter section in a zero-IF receiver is the main limiting block in IM2 products suppression. This is true if the baseband stages following the I/Q mixers have high common mode suppression (> 60dB).

### IIP<sub>2</sub> Derivation

The weakly non-linear characteristics of a receiver front-end can be presented as (Eq. 1):

$$V_o(t) = a_1 \cdot V_i(t) + a_2 \cdot V_i(t)^2 + a_3 \cdot V_i(t)^3 + \dots$$

To express the IIP<sub>2</sub> based on two-tone

derivation, the input signal to the receiver as shown in Figure 2 is expressed as  $V_i = A \cdot \cos(\omega_1 t) + \cos(\omega_2 t)$ , with a total two-tone power equal to  $A^2/R$ . The second-order distortion products at the receiver front-end are derived as: (Eq. 2)

$$a_2 \cdot V_i(t)^2 = a_2 \cdot A^2 \cdot [1 + \cos((\omega_1 - \omega_2)t) + \cos((\omega_1 + \omega_2)t) + (\cos(2\omega_1 t)/2) + (\cos(2\omega_2 t)/2)]$$

The resultant output IM2 products at  $(f_1+f_2)$  and  $(f_1-f_2)$ , including the resulting DC offset, are expressed as (Eq. 3):

$$a_2 \cdot A^2 \cdot [1 + \cos((\omega_1 - \omega_2)t) + \cos((\omega_1 + \omega_2)t)]$$

The total power in the output IM2 prod-

ucts presented in Equation 3, referred to system impedance R, is calculated as (Eq. 4):

$$|a_2|^2 \cdot A^4 \cdot \left( \frac{1}{R} + \frac{1}{2R} + \frac{1}{2R} \right) = 2 \cdot |a_2|^2 \cdot \frac{A^4}{R}$$

By definition, at the IIP<sub>2</sub> power level, the total input signal power is equated to the total power in the output IM2 products (Eq. 4) after being referred to the input by dividing by the gain factor,  $|a_1|^2$ . As a result, we can write that (Eq. 5):

$$A_{\text{IP2}}^2 / R = 2 \cdot \left| \frac{a_2}{a_1} \right|^2 \cdot \frac{A_{\text{IP2}}^4}{R} \Rightarrow \text{IIP}_2 = \frac{A_{\text{IP2}}^2}{\left( \left| \frac{a_1}{a_2} \right|^2 \cdot \frac{1}{2R} \right)} \Rightarrow \text{IIP}_2 = \left| \frac{a_1}{a_2} \right|^2 \cdot \frac{1}{2R}$$

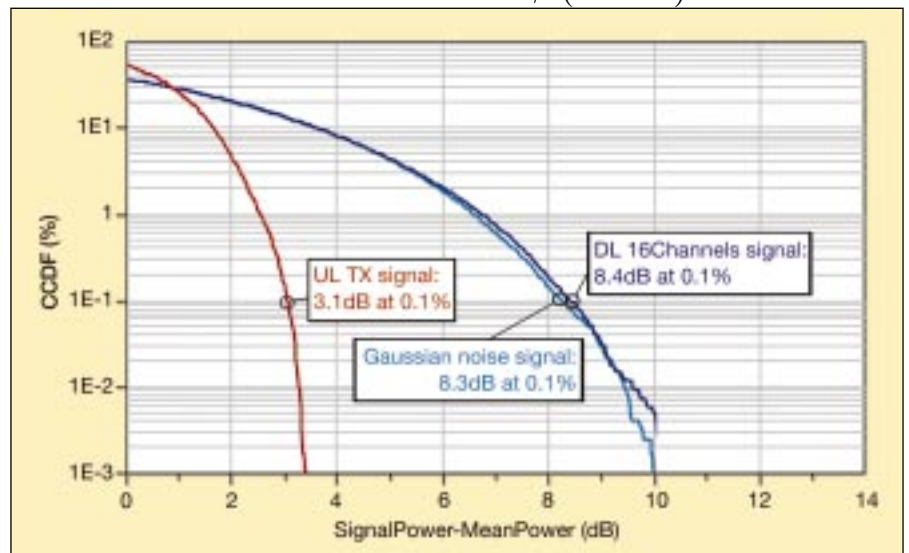

Figure 3. CCDFs of UL reference channel and DL 16-channel blocker.

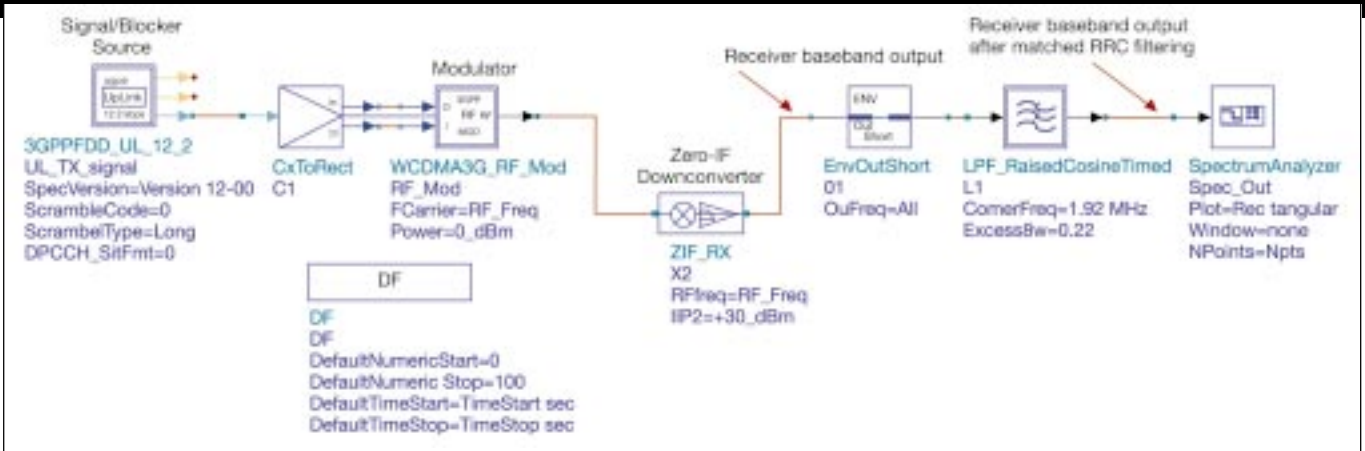

Figure 4. ADS template for IM2 products estimation.

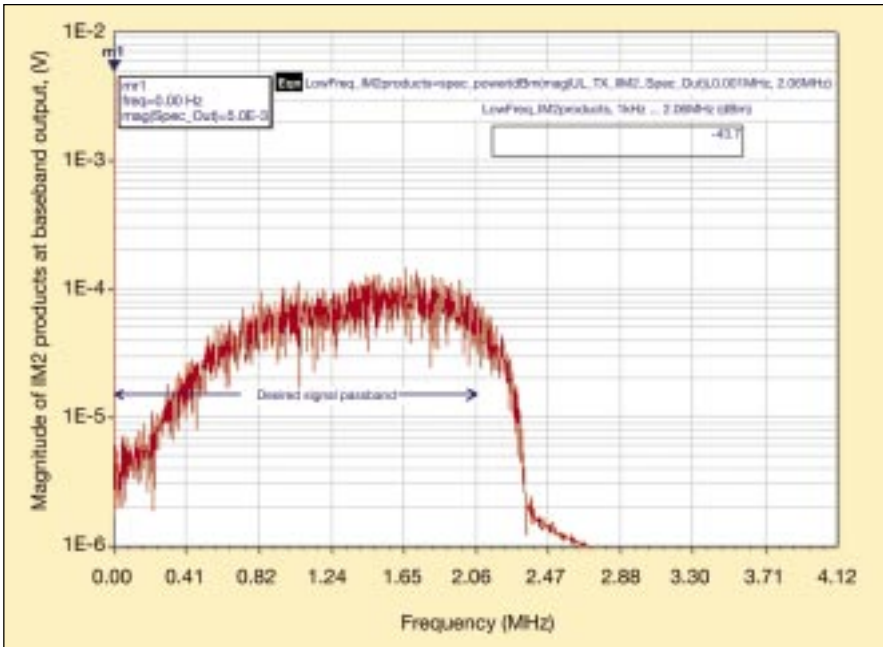

Figure 5. Simulated RRC-filtered IM2 products at zero-IF receiver output due to UL TX blocker.

The total power level of the IM<sub>2</sub> products (Equation 4) referred to the receiver input, based on a total two-tone input power equal to  $P_{2T} = A^2/R$ , can be expressed as (Eq. 6):

$$P_{IM2} = 2 \cdot \left| \frac{a_2}{a_1} \right|^2 \cdot \frac{A^4}{R} = \frac{P_{2T}^2}{IIP_2} \Rightarrow P_{IM2} \text{ (dBm)}$$

$$= 2 \cdot P_{2T} \text{ (dBm)} - IIP_2 \text{ (dBm)}$$

It is important to note that in Equation 4, the resulting IM<sub>2</sub> products total power level is composed of 50% (-3dB) IM<sub>2</sub> product at DC, 25% (-6dB) IM<sub>2</sub> product at  $f_1 - f_2$ , and 25% (-6dB) IM<sub>2</sub> product at  $f_1 + f_2$ . Therefore, the power level of the IM<sub>2</sub> product at  $f_1 - f_2$  can be derived from equations (4) and (6) as (Eq. 7):

$$P_{IM2, (f_1 - f_2)} \text{ (dBm)}$$

$$= 2 \cdot P_{2T} - IIP_2 - 6\text{dB} \Rightarrow P_{IM2, (f_1 - f_2)} \text{ (dBm)}$$

$$= 2 \cdot P_{IT} \text{ (dBm)} - IIP_2 \text{ (dBm)}$$

where power level per tone ( $P_{IT}$  at  $f_1$  or  $f_2$ ) is 50% of the total two-tone power,  $P_{IT} \text{ (dBm)} = P_{2T} \text{ (dBm)} - 3\text{dB}$ .

### Effective low-frequency IM<sub>2</sub> products

In a 3GPP WCDMA radio, the worst-case interferers at receiver input are not two-tone type but wideband, digitally modulated type blockers. Hence, it is important to estimate the effective low-frequency IM<sub>2</sub> products based on a modulated blocker to derive the required receiver IIP<sub>2</sub> for a certain desired bit error rate (BER) performance. Therefore, it is necessary to understand the nature of the modulated blocker, specifically its non-constant envelope since it gets stripped off the RF blocker in the front-end second-order non-linearity and gets translated to baseband, including a squared version of the envelope. The two major modulated blockers in a 3GPP WCDMA receiver are presented in 3G standard test cases 7.3.1 and 7.6.1 [4]. The first

test case, 7.3.1, specifies the minimum required sensitivity for BER < 10<sup>-3</sup> while the transmitted uplink signal (UL) is at maximum power level (+24dBm) at antenna. The second test case, 7.6.1, specifies the minimum required receiver signal level at antenna connector for BER < 10<sup>-3</sup> in the presence of a modulated downlink (DL) -44dBm blocker at 15 MHz offset from the desired signal, while the transmitted UL power at antenna is +20 dBm.

The UL reference measurement channel (12.2 kbps) structure, which represents the transmitted UL signal at the antenna of a 3G WCDMA handset, is described in table A.1 of the 3GPP standard document [4]. It consists of a dedicated data channel (DPDCH) and of a dedicated physical control channel (DPCCH). In the radio modem section, both DPDCH and DPCCH channels are spread to 3.84 Mcps, scaled to appropriate power ratio (DPCCH/DPDCH = -5.46 dB), HPSK scrambled, and filtered by a 1.92 MHz root-raised-cosine (RRC) filter with roll-off factor  $\alpha = 0.22$  [5]. On the other hand, the forward-channel modulated blocker at 15 MHz offset from the desired channel consists of the common channels needed for tests as specified in Table C.7 and 16 dedicated data channels as specified in Table C.6 in [4]. The signal is QPSK encoded, spread to 3.84 Mcps, complex scrambled, and filtered by a RRC filter similar to that used for UL signal [5]. Both signals have a -3 dB bandwidth equal to 3.84 MHz at RF, and 99 percent of the total signal power is within a bandwidth of 4.12 MHz (-6 dB BW). To understand the nature of the envelope of either the modulated UL TX signal or the modulated DL 16-channel signal—and to estimate the effective IM<sub>2</sub> products due to each one of them in a WCDMA Zero-IF receiver—it is important to study first the power statistics of each signal, which is represented by the complementary cumulative distribution function (CCDF). The CCDF provides the peak-average power ratio (PAR) of the signal vs. probability. Figure 3 shows ADS [6] simulated CCDFs of the UL trans-

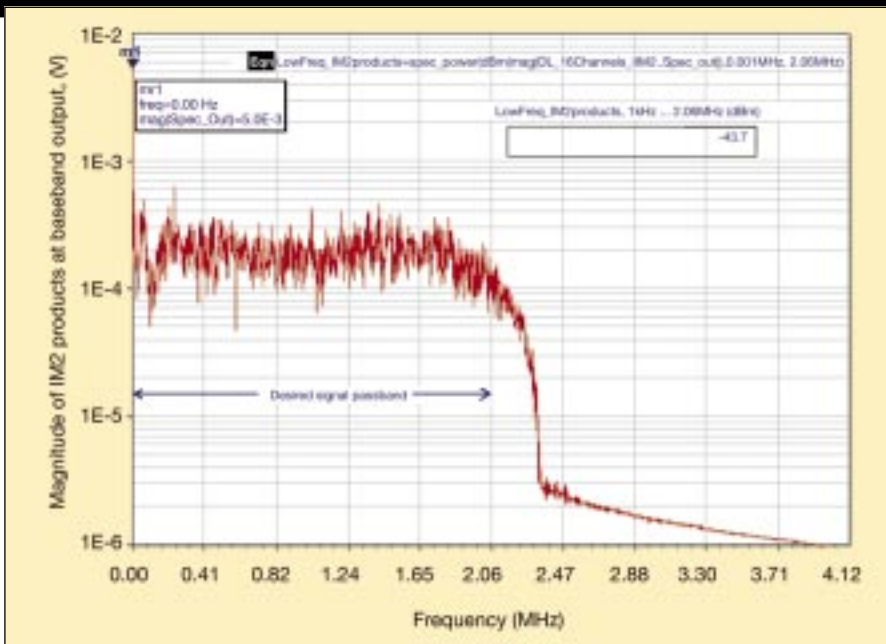

Figure 6. Simulated RRC-filtered IM2 products at zero-IF receiver output due to DL 16-channel blocker.

mitted signal and the DL 16-channel signal compared to the CCDF of a Gaussian noise signal.

Figure 3 shows the PAR at 0.1 percent probability of the UL reference channel, based on one transmitted DPDCH, is equal to 3.1 dB. On the other hand, the DL blocker at the 15 MHz offset, which contains 16 dedicated traffic channels, has an 8.4 dB PAR at 0.1%, which is almost equal to that of a Gaussian noise signal. It will be shown later that the effective low-frequency IM2 products estimation will differ between the two standard test cases because of this PAR discrepancy between the two different blockers.

An ADS IM2 simulation template was created to investigate the IM2 products due to a modulated blocker at the input of a WCDMA zero-IF receiver (Figure 4); the IM2 products were filtered by an RRC filter, which is matched to the base station transmitter RRC filter. The resulting low-frequency IM2 products were measured in simulation in the 0 Hz to 2.06 MHz desired signal bandwidth at baseband, which is half the signal's 99% power BW at RF.

In Figures 5 and 6, simulated IM2 products' magnitude spectrums at the baseband output of a zero-IF downconverter after matched RRC filtering are presented for the WCDMA UL reference measurement channel (12.2kbps) and for the WCDMA DL 16-channels blocker, respectively. In the ADS template and for simulation purposes only, we used a modulated blocker power equal to 0 dBm and a zero-IF downconverter  $IIP_2$  equal to +30 dBm. The resulting low-frequency IM2 products' power level for a 0 dBm WCDMA UL TX signal, integrated over the desired signal passband of 1 kHz ... 2.06 MHz, is equal to -43.7 dBm. The DC

offset due to second-order non-linearity is equal to 5 mV, which is equivalent to -33 dBm into 50 W (Figure 5). On the other hand, the resulting IM2 products' power level for a 0 dBm WCDMA DL 16-channel blocker, integrated over the desired signal passband of 1 kHz ... 2.06 MHz, is equal to -33.1 dBm. The resulting DC offset due to second-order non-linearity is also equal to 5 mV (Figure 6). Going back to Equation 6 and assuming a two-tone blocker total power level of 0 dBm at the zero-IF downconverter input, the total IM2 products' power level, referred to receiver input, is calculated as  $P_{IM2}(dBm) = 2 \cdot P_{2T}(dBm) - IIP_2(dBm) = -30dBm$ , of which -33 dBm is the resulting DC offset level and -36 dBm is the power level of the IM2 product at  $f_1 - f_2$ , based on Equations 4 and 7, respectively. We can conclude that the integrated low-frequency IM2 products' power level over the 1 kHz to 2.06 MHz band due to a 0 dBm UL TX blocker is 7.7 dB lower than the low-frequency,  $f_1 - f_2$ , IM2 product power level due to a two-tone blocker with 0 dBm equivalent power level. Similarly, the equivalent total low frequency IM2 product power level due to a 0 dBm DL 16-channel blocker is 2.9 dB higher than the low-frequency,  $f_1 - f_2$ , IM2 product power level due to a 0 dBm two-tone blocker. The total effective IM2 product power levels based on the previous results are summarized in the following equations:

For the UL reference channel or TX blocker case (Eq. 8),

$$\begin{aligned} P_{IM2, 2UL\_TX} (dBm) &= 2 \cdot P_{UL\_TX} (dBm) - IIP_2 (dBm) - 13.7dB \\ &= 2 \cdot P_{IT} (dBm) - IIP_2 (dBm) - 7.7dB \end{aligned}$$

For the DL 16-channel blocker case

(Eq. 9),

$$\begin{aligned} P_{IM2, DL\_16Ch} (dBm) &= 2 \cdot P_{DL\_16Ch} (dBm) - IIP_2 (dBm) - 1dB \\ &= 2 \cdot P_{IT} (dBm) - IIP_2 (dBm) + 2.9dB \end{aligned}$$

In Equations 8 and 9, the power level per tone ( $P_{IT}$  at  $f_1$  or  $f_2$ ) is 50% of the total power level ( $P_{2T}$ ) of a two-tone blocker having the same power level as that of the modulated blocker.

$$P_{IT} (dBm) = P_{2T} (dBm) - 3dB = P_{UL\_TX / DL\_16Ch} (dBm) - 3dB$$

It is important to note that the -13.7 dB reduction factor relative to the total IM2 products' level estimate in Equation 8 is similar to the factor obtained in the results presented in [7]. Furthermore, the results presented by Equations 8 have been verified through lab measurements done on a zero-IF receiver device with the part number shown in Figure. 1. The measured IM2 products at baseband due to UL TX blocker (Figure 7) show similar spectrum characteristics to the simulated IM2 products shown in Figure 5. The measured spectrum components close to DC in Figure 7 are larger than the corresponding simulated components in Figure 5 because of the additional downconverted phase noise close to DC in the actual measured zero-IF receiver.

### Minimum $IIP_2$ requirements for a WCDMA receiver

In the following section, the required minimum  $IIP_2$  for a WCDMA zero-IF receiver for both test cases 7.3.1 and 7.6.1 will be derived based on Equations 8 and 9, respectively. All  $IIP_2$  calculations are done referred to the receiver LNA input.

#### -3GPP standard test case 7.3.1:

■ In FDD mode, the estimated maximum UL TX signal leakage at the LNA input is -24 dBm ( $P_{UL\_TX, LNA} = PA$  power at duplexer - duplexer\_isolation<sub>TX→RX, min.</sub> = +26dBm - 50dB = -24 dBm). The worst-case insertion loss (IL) of the duplexer before the LNA is assumed equal to -2 dB. In 3GPP IMT band radio handsets, the TX leakage frequency offset relative to the desired RX signal frequency is 190 MHz.

■ It was shown in [8] that for a required traffic channel sensitivity of -117 dBm/3.84 MHz, the required minimum  $E_b/N_t$ , after decoding and despreading of the desired traffic channel, is 7 dB. In test case 7.3.1, which specifies the minimum required traffic channel sensitivity for  $BER < 10^{-3}$ ,  $N_t$  is assumed to be purely noise ( $N_o$ ) due to receiver NF. For a chip rate of 3.84 Mcps and a user bit rate of 12.2 kbps, the processing gain is  $G_p = 10 \cdot \log(3.84 \text{ Mcps} / 12.2 \text{ kbps}) = 25 \text{ dB}$ . We can calculate that the maximum allowable noise power ( $P_N$ ) due to receiver NF is  $P_N = P_{Sensitivity} + G_p - E_b/N_t = -117 \text{ dBm} + 25 \text{ dB} - 7 \text{ dB} = -99 \text{ dBm}$ .

■ At minimum sensitivity level, it is required

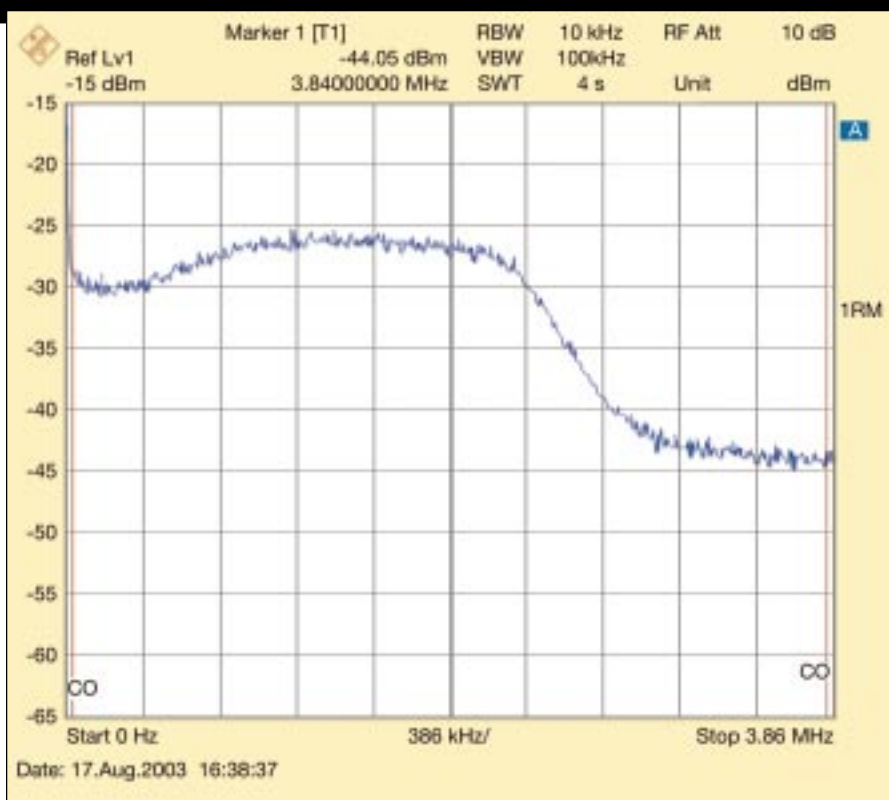

Figure 7. Measured IM2 products, without RRC filtering, at zero-IF receiver output due to UL TX blocker.

that the low-frequency IM2 products due to UL TX leakage blocker do not desensitize the receiver. The resulting DC offset due to IIP<sub>2</sub> has no effect since in a WCDMA zero-IF receiver, DC offsets are typically rejected on-chip. If we assume that the total power level of low-frequency IM<sub>2</sub> products needs to be at least 11 dB lower than P<sub>N</sub> (maximum of 0.3 dB receiver desensitization), we can estimate the maximum allowable input IM2 due to UL TX leakage blocker, referred to receiver LNA input:

$$P_{IIM2,UL\_TX} = P_N - 11\text{dB} - IL_{\text{duplexer}} \leq -99\text{dBm} - 11\text{dB} - 2\text{dB} = -112\text{dBm}.$$

■ The receiver IIP<sub>2,TX</sub> at TX offset (190 MHz), referred to receiver LNA input, is calculated using Equation 8:

$$P_{IIM2,UL\_TX}(\text{dBm}) = 2 \cdot P_{UL\_TX,LNA}(\text{dBm}) - IIP_{2,TX}(\text{dBm}) - 3.7\text{dB} \\ \Rightarrow IIP_{2,TX}(\text{dBm}) \geq +50\text{dBm}$$

-3GPP Standard Test Case 7.6.1:

■ In this test case, the desired signal is 3 dB above minimum sensitivity specified in test case 7.3.1. Hence, the maximum allowable noise+interference power level is -96 dBm, which is 3 dB higher than the level calculated in the previous test case. Assuming the same level of receiver noise (-99 dBm), the maximum allowable interference power level is therefore 96 dBm - 3 dB = -99 dBm.

■ The total interference power due to the WCDMA DL 16-channel blocker at 15 MHz offset from the desired signal is assumed to be divided mainly among phase noise recip-

rocal mixing (25% or -6 dB), blocker level at receiver output after on-chip filtering (25% or -6 dB), and low-frequency IM2 products due to this blocker (50% or -3 dB). Hence, we can estimate the maximum allowable input IM2 products' level due to DL blocker, referred to receiver LNA input: P<sub>IIM2,DL\_16Ch</sub> = P<sub>N</sub> - 3dB - IL<sub>duplexer</sub> ≤ -99dBm - 3dB - 2dB = -104 dBm. The low-frequency IM2 products due to the UL TX leakage signal have been neglected because the UL TX power in this test has been reduced by 4 dB relative to the level specified in test case 7.3.1.

■ In this test case, the specified modulated blocker level is equal to -44 dBm at the antenna. With -2 dB IL in duplexer, the level of the blocker at LNA input, P<sub>DL\_16Ch,LNA</sub>, is -46 dBm.

■ The receiver IIP<sub>2,(15MHz)</sub> at 15MHz offset, referred to receiver LNA input, is calculated using Equation 9:

$$P_{IIM2,DL\_16Ch}(\text{dBm}) = 2 \cdot P_{DL\_16Ch,LNA}(\text{dBm}) - IIP_{2,(15MHz)}(\text{dBm}) - 3.1\text{dB} \\ \Rightarrow IIP_{2,(15MHz)}(\text{dBm}) \geq +9\text{dBm}$$

-3GPP Standard Test Case 7.6.1:

It is important to note that the required zero-IF receiver IIP<sub>2,TX</sub> at the UL TX frequency offset is much tougher than the required IIP<sub>2,(15MHz)</sub> at the DL 16-channel blocker frequency offset, when all are referred to LNA input. When translating the IIP<sub>2,TX</sub> requirement to the I/Q mixers inputs, this will impose the need for the mixers' IIP<sub>2,I/Q\_mixer</sub> to be larger than +60 dBm. However, this require-

ment can be relaxed by the use of the post LNA filter, which provides selectivity at the TX leakage offset frequency [9].

## Conclusions

This paper presented simulations, calculations, and measurements, which were done to estimate the required zero-IF receiver IIP<sub>2</sub> in the presence of a modulated WCDMA blocker. Depending on the envelope nature of the modulated blocker, it has been shown that the resulting low-frequency IM2 products' level at baseband can be lower or higher than the low-frequency IM2 beat tone level due to an equivalent two-tone blocker. RFD

## References

1. Behzad Razavi, "Design Considerations for Direct-Conversion Receivers," *IEEE Transactions on Circuits and Systems - II: Analog and Digital Signal Processing*, Vol. 44, No. 6, pp. 428 - 435, June 1997.
2. Aravind Loke and Fazal Ali, "Direct Conversion Radio for Digital Mobile Phones - Design issues, status, and trends," *IEEE Transactions on Microwave Theory and Techniques*, Vol. 50, pp. 2422-2435, No. 11, November 2002.
3. Danilo Manstretta et F.Svelto, "Analysis and Optimization of IIP2 in CMOS Direct Down-Converters," *2002 IEEE Custom Integrated Circuits Conference*, Orlando, FL, May 2002, pp. 243 - 246.
4. 3<sup>rd</sup> Generation Partnership Project, "UE Radio Transmission and Reception (FDD), Technical Specification GRAN", TS 25.101, V5.7.0 (Release 5, June 2003).
5. 3<sup>rd</sup> Generation Partnership Project, "Technical Specification GRAN, Spreading and Modulation (FDD)", TS25.213, Release 5.
6. Advanced Design System, (ADS) is a trademark of Agilent Technologies, 395 Page Mill Road, Palo Alto, CA 94304.
7. B.J. Minnis et al., "Estimating the IP2 requirement for a zero-IF UMTS receiver," *Microwave Engineering*, July 2002, pp. 31 - 36.
8. TSG-RAN Working Group 4, Nokia Mobile Phones, "MS Receiver Sensitivity in UTRA FDD mode," Document TSGW4 #1(99)012, January 1999.
9. Walid Y. Ali-Ahmad, "Improving the receiver intercept point using selectivity," *RF Design*, December 1997, pp. 22 - 30.

## ABOUT THE AUTHOR

**Walid Y. Ali-Ahmad** Ph.D. is a senior member of the technical staff at Maxim Integrated Products in the wireless communications division. He is currently working on the architecture definition and system design of next-generation cellular radio RF chipsets, as well as radio system reference designs for 3G WCDMA and TD-SCDMA handsets. He can be contacted via e-mail at walid\_ali-ahmad@maximhq.com.