

Direct-sequence UWB signal generation and measurement

This article discusses how to generate and measure ultra-wideband signals to design and test the performance of radio receivers handling UWB signals. A number of novel techniques, such as pulse shape recovery and frequency measurements on sub-nanosecond pulses, are described using modern test equipment.

By Peter Cain

Ultra-wideband (UWB) radio signals have characteristics that are different from conventional radios. Of special interest is the ability to spread the transmission power over a sufficiently wide bandwidth to make the signal appear as noise to a narrowband receiver, while still being able to transmit very high data rates over short distances. In this context "narrowband" may actually mean 20 MHz wide.

A direct (baseband) pulsed approach, using today's ultrahigh-speed digital circuitry, was originally seen as the most direct route for UWB radio implementation. However, in order to design a mass-producible radio, ideas have migrated to combine frequency

ware testing during design and evaluation. A number of novel techniques, such as pulse shape recovery and frequency measurements on sub-nanosecond pulses, are described.

As with any radio, as well as testing the modulation and time characteristics of the signal, the designer will have to ensure the spectrum emissions fit within regulatory allowances. UWB regulation recognizes the noise-like nature of the signal by requiring the use of the average (rms) detector feature of modern spectrum analyzers. The article concludes with a description of how and why the results can be different to those the reader may be expecting, since the peak detector

has historically been the most widely used detector type.

Pulse-modulated RF

Although very wide, the UWB transmission still has to fit within a defined spectral window. Examination of the pulse waveforms needed to create a banded spectrum shows they look like bursts of a few cycles of a carrier. For example, the simplest extension from the bipolar pulse to a Gaussian monopulse reveals how it looks like a cycle of a single sine wave in the time domain.

This points to the use of conventional frequency mixing as a way to generate the UWB signal, and is what has become the more popular approach. To remove some of the mystery of UWB, it can be useful to understand the transition

As with any radio, as well as testing the modulation and time characteristics of the signal, the designer will have to ensure the spectrum emissions fit within regulatory allowances.

upconversion and downconversion. This significantly eases the issue of spectrum emission control, and the requirements for the receiver's analog-to-digital conversion (ADC). While developments are under way for orthogonal frequency division multiplexing (OFDM) systems, pulsed and what is referred to as direct sequence-UWB (DS-UWB) continues to be of interest in practical devices and for experimental research.

In this article, we shall see what the RF signals look like for UWB pulsed signals and those intended for the IEEE 802.15.3a DS-UWB proposal. It is important to note these are still evolving, and IEEE 802.15.4a may use similar RF techniques, so the measurements shown are not specific to one specification. It will be shown how it is possible to generate and measure the signals to allow hard-

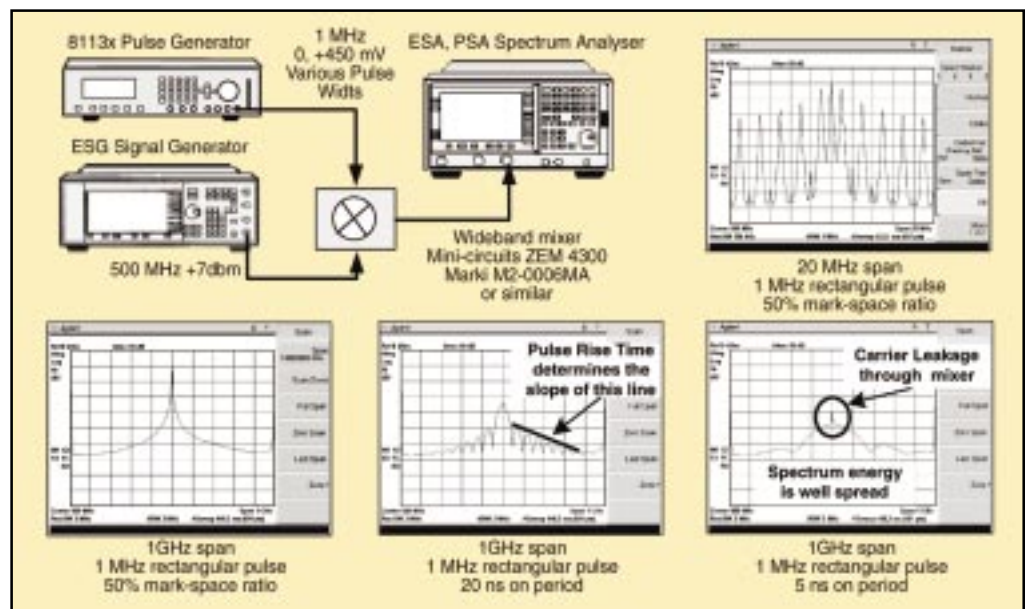

Figure 1. Spectra of a pulsed 500 MHz carrier with different turn-on periods. The carrier leakage circled in the lower right plot is due to imperfect mixer balance.

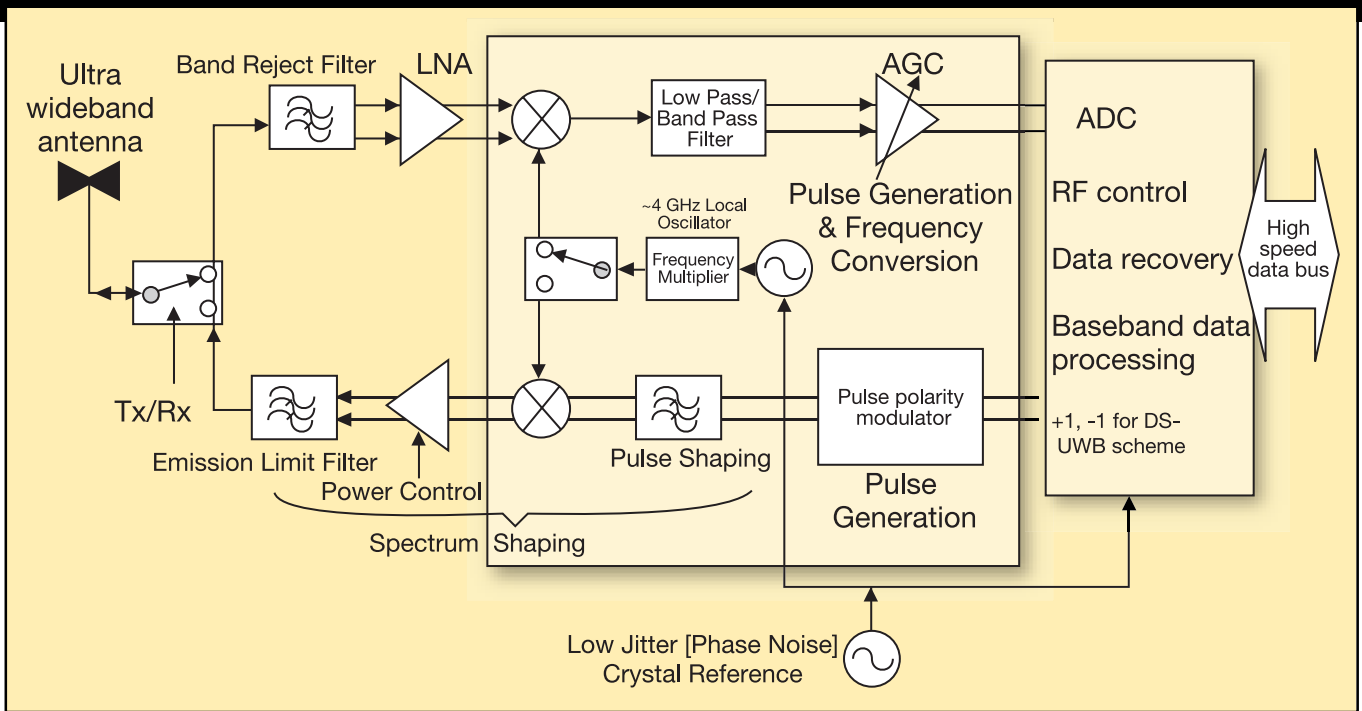

Figure 2. Block diagram of a pulse-modulated RF UWB radio.

from the narrowband signals we are used to, to a “UWB” signal. Figure 1 shows a series of practical spectrum analyzer traces that track the change in the displayed spectrum as a local oscillator is switched on for progressively shorter periods.

In the lower row of traces, we see how the energy gets distributed broadly across the spectrum as the on-period of the local oscillator is reduced to the point where there are only a few cycles of the carrier (2.5 in this case). The peak of power centered on 500 MHz is dramatically reduced as the signal changes from narrow to ultra-wideband. It is predictable using Fourier analysis, but few RF engineers will have had reason to experiment with pulses this narrow. Pulse modulation usually involves hundreds of cycles of the carrier.

The transition from discrete spectral lines to a “continuous” spectrum display is due to the ratio of measurement span (bandwidth of the signal) and the resolution filter of the spectrum analyzer. In broad terms, the inability of the spectrum to resolve individual line spectra is equivalent to how we want a real-world narrowband radio to respond to the UWB signal. Going to the next level of detail, while it is the pulse shape that determines the overall shape of the spectrum (see the lower center section of Figure 1), it is the spacing of the pulses that determine how noise-like the UWB signal will be. We shall see later how this is built into one of the proposals, and can be tested.

Figure 2 shows a simplified block dia-

gram for a UWB radio based on frequency mixing. On paper the implementation looks more complicated than a filtered pulse generator, but multiplying a shaped pulse by a fixed carrier eases some of the significant problems of realizing economical but reproducible performance. Out-of-band spurious signals must be consistently kept at low levels. An added advantage for this circuit is that to generate a given instantaneous RF signal bandwidth, only half that value of bandwidth is needed at baseband. In the time domain, this means the pulse rise time can be double that needed for a radio without frequency conversion, making real device performance more predictable.

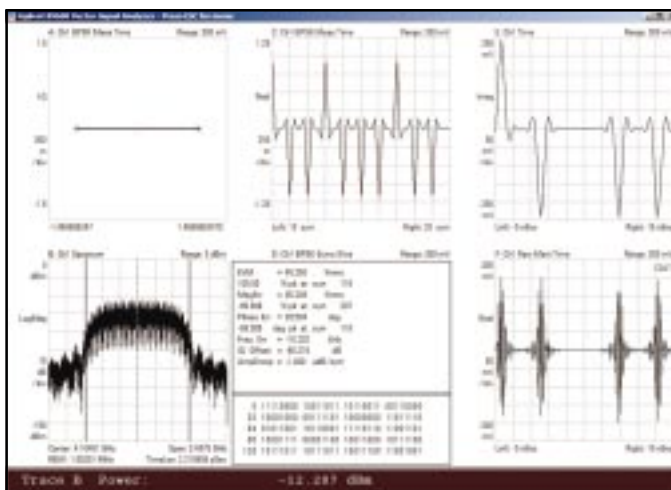

Figure 3. Digital demodulation applied to a three-state PSK pulsed signal.

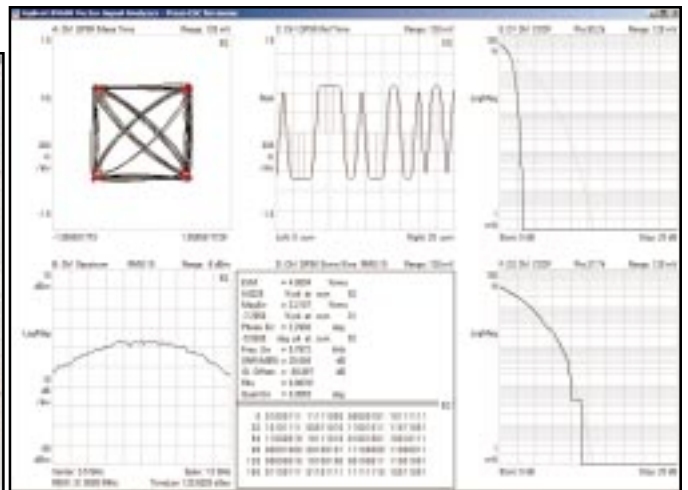

Figure 4. A 1 Gsymbol/second QPSK signal generated using the 81134 and PSG measured with the 10 GHz DSO81004A oscilloscope and 89601 VSA software. The power distribution plots on the right (CCDF) are described in the text.

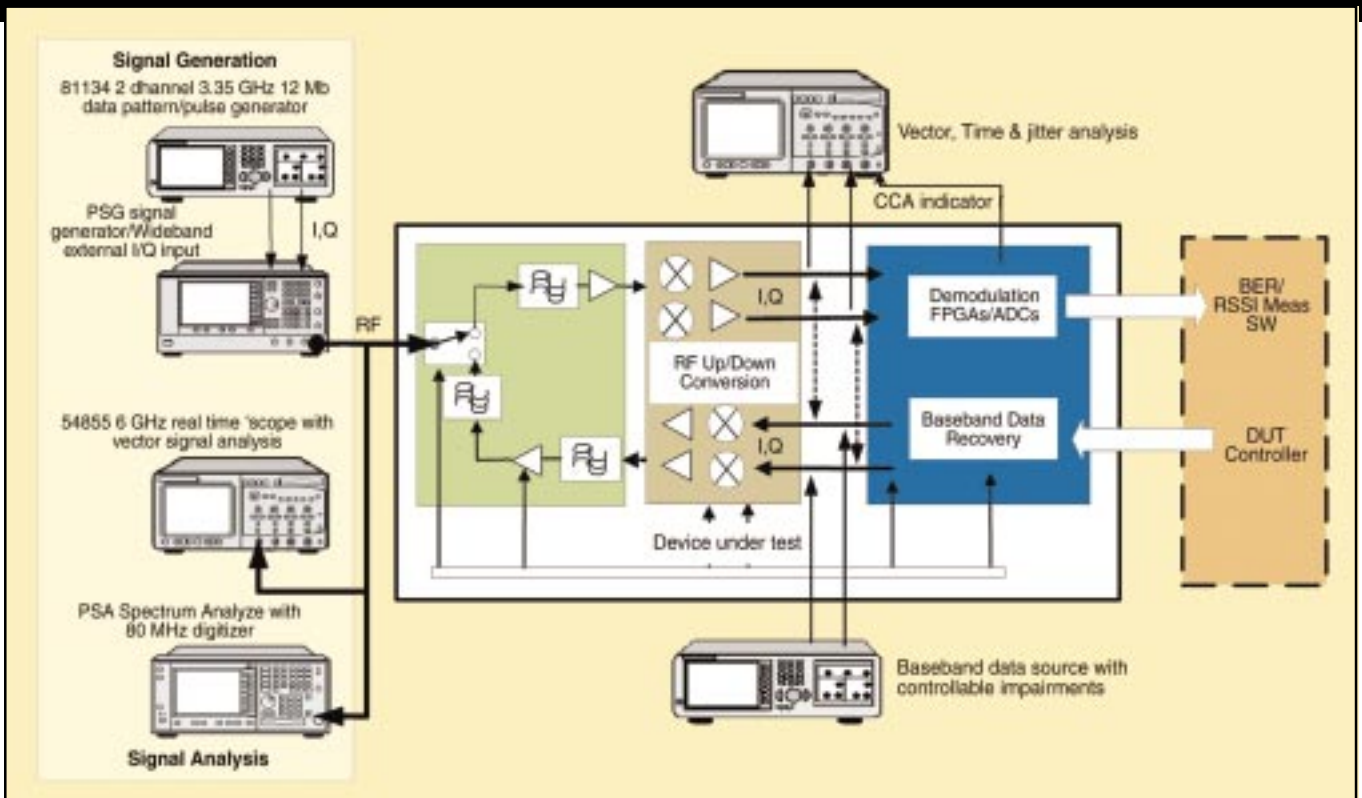

Figure 5. Combination diagram showing transmitter and receiver test configurations.

Transmitter path measurements

In Figure 2 we see how the RF front end looks similar to other time-division duplex radios. Differential signal paths are shown at various points to indicate how this has become an essential part of circuit design. Use of differential signals is progressively moving beyond the integrated circuit (IC) itself, which impacts the way we connect for measurements. Differential RF probes become more a requirement than a luxury.

In the transmitter, shown in the lower half of the diagram, the usual issues of signal generation apply, but the speeds of the baseband signals have gone up dramatically. Separation of different signals using frequency selective filtering is harder because the ratio of the wanted and unwanted frequencies is much lower. Close attention to signal path loops is essential.

A spectrum analyzer can be used for checking the level and leakage of fixed frequency components such as clock harmonics and phase noise. Generally test modes are used to isolate these parameters, and these can be extended for specific modulation bandwidth

tests. For example, certain baseband test patterns can be chosen to give specific RF spectral shapes, which the spectrum analyzer can then show.

However, there is a limit to what narrow-band analysis can show if we want to examine the operation of the whole signal path. Errors and distortions add as vectors, but using conventional swept spectrum analyzers we only view the resultant power. Even with the newer digital spectrum analyzers, the widest bandwidth signals they can fully characterize are limited to about 100 MHz. A measurement tool with greater than 1000 MHz bandwidth is needed.

Fortunately, this tool is available in the form of a digitizing oscilloscope. What is more important is that the signal can be measured and analyzed using advanced RF techniques. Figure 3 shows different aspects of a pulsed UWB RF signal that has been captured with a 10 GHz real-time oscilloscope, using a vector signal analysis package running within the oscilloscope. The measurement suite available within the scope now crosses the baseband and RF boundary, with everything from digital demodulation of the RF signal, to jitter analysis. A 10 GHz differential probing system completes the tool kit.

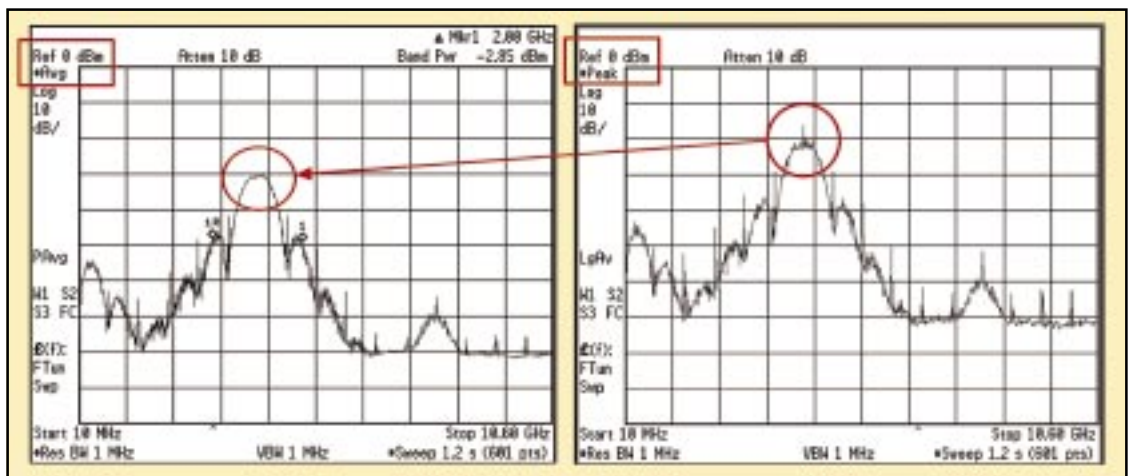

Figure 6. A UWB signal with unwanted clock harmonics measured (left) with an average detector and (right) with a peak detector. The carrier frequency leakage identified in the right hand plot is "missing" in the left hand plot because of the different operation of the peak and average detector.

Measurements of a three-level phase shift keyed test signal

Unlike a baseband pulsed radio, the voltage of the transmitted RF waveform, as seen on a normal oscilloscope and in the lower right trace of Figure 3, no longer shows the shape of the pulse. Pulse shape and phase measurements require the signal to be demodulated. The software used in Figure 3 removes the RF carrier and in the upper right trace of Figure 3 shows the resultant wave-

form, both on 2 ns/div scales. In this case, it shows the shape of the root raised cosine filtering used to give the desired spectrum shape. The approximately rectangular spectrum is also displayed in the lower left section of Figure 3 and the total power is shown numerically at the bottom.

The analysis that's available goes further. The signal was an example of a three-level phase shift keyed (PSK) signal. This is one of kind of signal that has been proposed for

UWB radio use. By treating it as binary phase shift keying (BPSK), we can demodulate it. (This also works for ASK). The three states can be seen in the IQ plot at the top left of Figure 3, and the demodulated components are shown in the two center traces. In this case, the "0" state is not recognized correctly, so the numeric error vector magnitude (EVM) readings are not meaningful, but other useful information can be seen that will allow the differentiation between clean and noisy signals. By considering the pulsed signal as BPSK and entering a symbol period that matches the clock frequency of the baseband signal, even the frequency error can be measured. Measurement of frequency under dynamic conditions is frequently more revealing than with the device in a continuous wave (CW) test mode. If the reader imagines trying to measure the frequency from the oscilloscope trace in the lower right section, it can be seen how powerful the software analysis is. The result in this example is shown within the rectangle in the lower center box. A 10 kHz offset was deliberately added to the simulation, which is centered at 4104 MHz.

Returning to the pulse shape in the top left of Figure 3, for sub-nanosecond pulses the displayed time resolution may affect the usefulness of the result. How significant this effect is depends on the actual bandwidth of the test signal. As an indication, the sampling rate for the demodulated result is one-third that of the original data capture. Part of this is due to the splitting into IQ data pairs, the rest is related to data windowing. The results may be enhanced using averaging, which increases the effective sampling rate if noise is present, which it will be. The trace data can also be extracted as a vector sequence for post processing.

Measurements of a DS-UWB signal

Generating a UWB signal that looks like noise means creating a pulse sequence that does not have significant repetition. As we further consider the radio implementation, we realize that simply speeding up some of the modulation techniques used for narrowband radio, like 802.11b, may be well suited to UWB. "Pulses" have been with us all along. We can pick a simple modulation type and then modulate the data in a format to suit the type of radio link we want to build.

The modulation clock rate has to be extremely high to provide the basic data capacity. The DS-UWB proposal for IEEE 802.15.3a¹ addresses the need for closely shaped pulses with long repeat intervals, by using code sequence modulation on an approximately 1300 MHz or 2600 MHz pulse stream. Modulation involves choosing between symbols made up of carefully chosen

data sequences, alternating between +1, -1, and possibly 0. These may be applied as BPSK or possibly as quaternary phase shift keying (QPSK).

Referring to Figure 2, a common crystal reference will be used for carrier and pulse timing, giving a fixed relationship between the carrier frequency and pulse period. Some designs may use a variety of local oscillator frequencies to provide the right combinations of spectrum usage and data throughput. Current IC technology and the need to avoid the 5 GHz to 6 GHz UNII bands means practical designs are being limited to <2 GHz of RF bandwidth, compared to the potential of 7 GHz made available by the spectrum regulators (in the United States at least).

The combination of oscilloscope and VSA software allows analysis of a range of modulation types. As a second UWB signal example, in this case a real signal, Figure 4 shows a “direct sequence” QPSK UWB signal at 3.5 GHz. The EVM metrics are valid, although an adaptive equalizer was used to simulate the reduction in linear distortions, similar to the capability of a normal receiver. The uncorrected EVM of the signal generator is higher. In addition to the measured signal, the top central trace shows how the software can display what the ideal real (or imaginary) waveform should look like.

The two right hand traces in Figure 4 reveal another aspect of the UWB signal, and one that is important when considering the co-existence of the UWB radio with narrowband receivers. The traces are of the complementary cumulative distribution function (CCDF), or more simply, give an indication of the statistics of the power of the radio signal. The grey curve shows the distribution of Gaussian noise, so the more the signal tracks this, the more noise-like it should be. In the top trace, the black curve shows a peak-to-average that is a lot less, but this measurement was made using the full signal bandwidth of 1.5 GHz, and what we see is the statistics of the pulse waveform shown in the top center trace. If we reduce the measurement span, which is akin to representing a narrowband receiver, the power distribution now does become noise-like. The dominant parameter to ensure this happens is the choice of the data coding that’s used.

Functional use of frequency error measurement

The frame design for the IEEE UWB radio proposals is similar to those for wireless local area network (WLAN), insofar as it consists of a preamble, header and payload. There are significant operational differences. For example, the design is for a wireless personal area network (WPAN), allowing for uncoordinated piconets. In the direct se-

quence design, these are identified by a small frequency offsets (~10 MHz) in the local oscillator. This is designed to be rapidly identifiable during the synchronization process. Being able to measure this on a complete device is a useful check for basic operation because if there is an error it may disrupt the rest of the receiver operation.

In recovering the data, the pulse data coding is such that it is the correlation of the

code sequence that is most important. Depending on the modulation type used, post processing of the captured, demodulated time record can provide time-correlation results too.

Receiver testing

The upper half of the diagram in Figure 2 shows the receiver path. Filtering out high-level narrowband interferers is one of the



big headaches with a UWB receiver. Post downconversion filtering provides some additional interference protection, but the intermediate frequency (IF) bandwidth has to be so wide it is not as effective as a normal narrowband radio. Having a test source that can emulate different narrowband signals is important.

The recovered pulse can be fed to an analog correlator or, as shown in Figure 2, sent

to an analog-to-digital converter (ADC). Digital signal processing on the ADC output is used to recover the original signal. Over time, designs may be able to take time of ever-faster ADCs to remove some of the analog processing.

For DS-UWB, it is the receiver's ability to correlate symbol pulse sequences that is more important than its response to individual pulses. Therefore, the exact spectral shape of

the test signal is not as significant for sensitivity testing as it would be if the source had to meet the transmitter test mask. The next nearest UWB channel is spaced more than 1 GHz away, with the 5 GHz to 6 GHz UNII band in between, so adjacent UWB channel testing is not significant in the normal way. Piconets are differentiated by small frequency offsets.

Each RF frame is recovered in isolation. The channel equalization is done on a small part of each frame, and may need to use only a few microseconds worth of data. Special care is required to ensure this part of the signal is stable relative to the remainder of the frame. It is useful to be able to deliberately impair the test source to see how robust the receiver is.

A DS-UWB (pulsed) RF source

As depicted in Figure 5, and with the results of Figure 4, a combination of a high-speed pulse per pattern generator and a wideband external I/Q option for a signal generator, can be used as a pulsed or direct sequence RF source. For simple formats like BPSK and QPSK, the uncorrected modulation accuracy of the PSG should be acceptable. The immediate benefit of using an integrated solution, in contrast to the simple external mixer arrangement in Figure 1, is that the level of the wanted RF is accurately controlled. The level of unwanted signal components is also defined. The high output power available from the signal generator may be useful for over-the-air experiments and testing. The signal generator can also double as a narrowband (e.g. WLAN) interferer, and have an additional impairment such as low-frequency FM added to represent local oscillator (LO) instability.

The dual channel 81134 can be configured to generate either a noise-like bipolar datastream using a pseudo random number (PN) sequence, or be programmed with a user-defined data pattern. Two channels used together with a timing offset will create the IQ signals needed for QPSK as shown in Figure 4. By locking the reference frequency of the 81134 and PSG, the user can deliberately impair the test signal and check the

ABOUT THE AUTHOR

As an engineer and project manager, Peter Cain has been involved with RF measurements and their associated hardware for more than 20 years. His current role is in planning new solutions for emerging technologies at Agilent Technologies. These have included Bluetooth, WLAN and most recently ultra-wideband. Cain has a degree in Electronic Engineering from the University of Southampton in England.

receiver's response in a repeatable manner.

To create the three level signals in one IEEE proposal, Channel 1 and Channel 2 of the 81134 are coupled using a power splitter. Using the data mode, the data patterns are programmed to provide the +1, -1, and 0 states required. The channel output voltage needs to be doubled to take account of the loss in the splitter. Timing differences between the channels can be corrected using the delay adjustment. A small DC offset may be needed to minimize carrier feed-through.

Spectrum mask testing— differences between peak and average detection modes

In general, measurement of the RF spectrum generated by a transmitter addresses two questions:

1. Will the device under test (DUT) interfere with other radio receivers?
2. Will the DUT work effectively with another of the same type?

The regulatory community is concerned with the first question, and many tests have been carried out to find out how to measure a UWB radio signal in a way that is practical and representative of its affect on other radio types. The conclusion to date is that a combination of peak and average detection is the best way to assess the output emissions. An average detector is best suited to accurately measure the power of noise-like signals, while the operation of the peak detector is designed to track narrowband signals quickly during swept analysis. Advanced testing may involve wideband (50 MHz) complementary cumulative distribution function (CCDF) measurements. These can be done using a digitizing option in the spectrum analyzer.

As noted in the receiver section, the wide "channel" spacing for DS-UWB means spectrum testing is not particularly relevant for interoperability issues. Multiple piconets use the same frequency range and are separated by data codes and small frequency offset.

Figure 6 shows the results of measuring a deliberately badly behaved DS-UWB-style transmitter. Along with the wanted UWB signal, there are a large number of clock leakage components. The result from the traditional peak detector on the right shows the unwanted spurious components. However, it does not allow the power level of the modulated signal to be correctly measured. In contrast, the trace on the left shows the correct output power (-2.85 dBm, top right), but some of the spurs have "gone." There is nothing wrong with the spectrum analyzer. It is the choice of frequency span, resolution bandwidth, and the number of display points that cause this to happen. Increasing the number of frequency points will help, but for practical tests it is best to get into the habit of

checking both detectors. Doing this has been made easier in recent software for the PSA spectrum analyzer because using the "UWB emissions" test, the display can be made to show both simultaneously.

Conclusion

UWB radios will shortly appear in consumer appliances and offer some unique combinations of data throughput and operating range. In this article we have seen how to use today's test equipment to measure the per-

formance of the radio, and thereby ensure the designs result in consistently performing hardware. Further details on a number of the topics discussed here can be found in the application note² referred to below. RFD

References

1. IEEE 802.15.3a Direct Sequence Proposals 2003-2004.
2. Ultra Wideband Communication RF Measurements Application Note 1488 Agilent Technologies.