

Phase-coherent test system for multireceiver applications

Evaluation of phased-array radars and other systems employing multiple receivers can now be performed without field testing with this system of phase-coherent signal generators that accurately simulates actual signal conditions.

By John Hutmacher

Testing of receivers and baseband algorithms in phased-array radars and other multireceiver systems has long been a complicated and expensive process. The receivers must be stimulated by a signal environment that accurately represents real-world conditions. These signal conditions are almost invariably different at the antenna of each receiver because each

one acquires the signal at a slightly different time, phase, amplitude and frequency—usually known as TDOA (time difference of arrival) or AOA (angle of arrival), as shown in Figure 1.

Until now, accurately producing these signal conditions has either required field testing or a complex, custom-built system. However, field testing is prohibitively expen-

sive and unrepeatable, and custom systems are difficult to build, verify and support. They also may not solve the problem of providing phase-coherence between the signal generators that output the stimulus signal to the receivers under test, which can cause errors in the receive system or can limit its resolution. A new alternative, constructed entirely of commercial equipment, is fully phase-

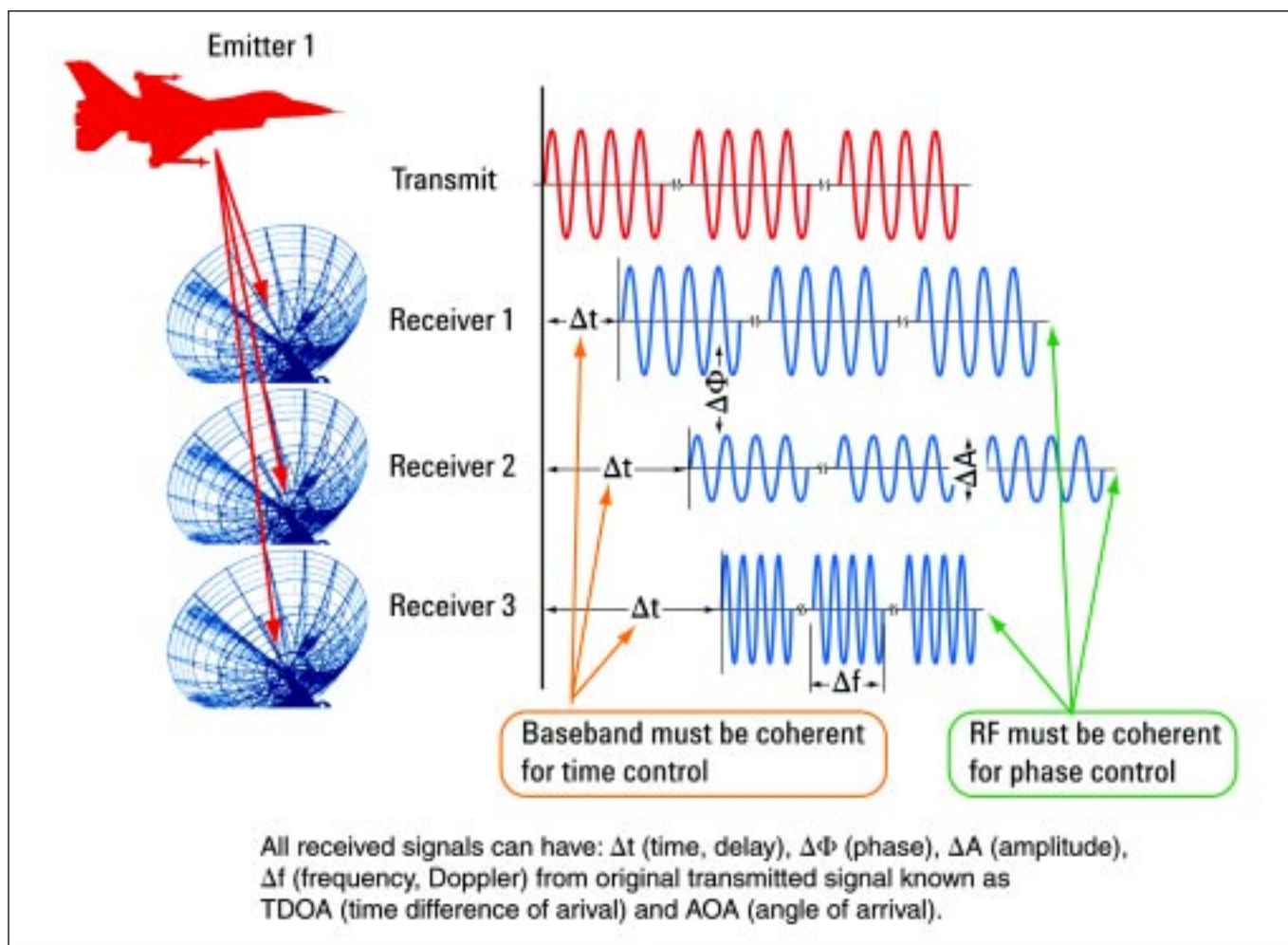

Figure 1. Each receiver in a system employing multiple receivers captures the signal at different times and with different characteristics.

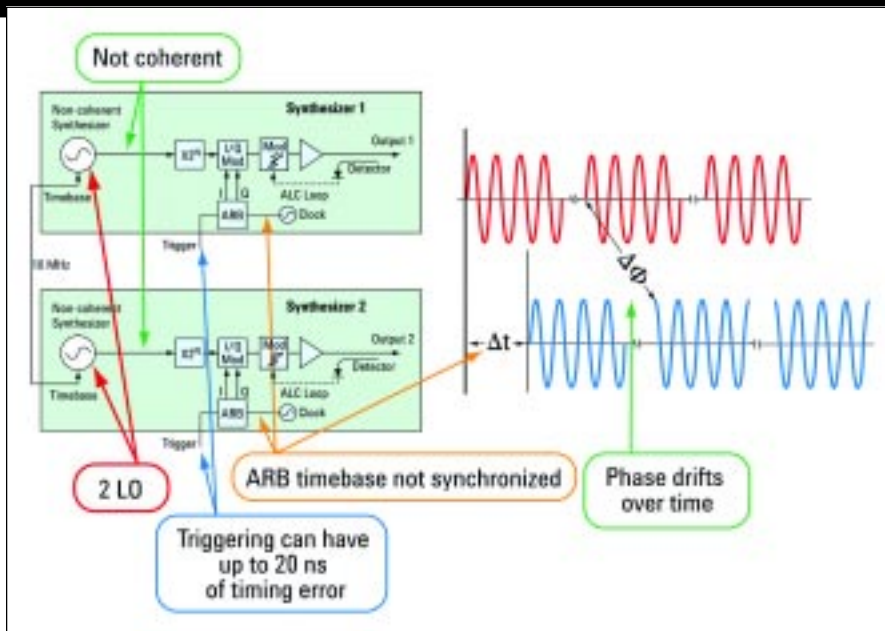

Figure 2. In an uncontrolled test system using multiple signal generators, the two local oscillators (LOs) will not be phase-locked together.

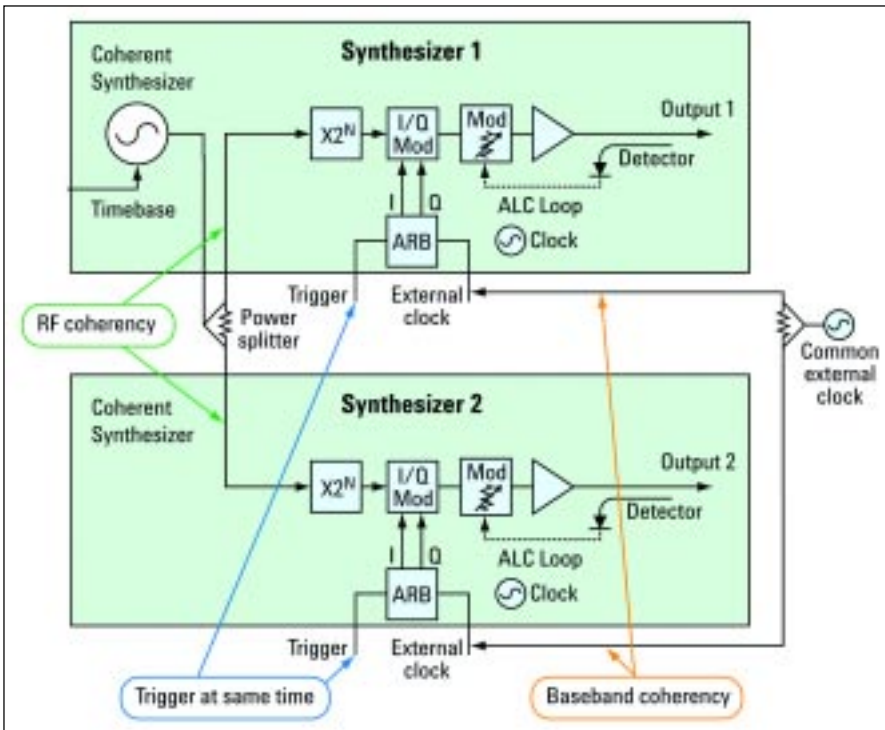

Figure 3. A system using independent signal generators to produce variants of a signal.

coherent and provides repeatable, accurate results by tightly controlling each signal generator in relation to others in the system.

Multiple receiver systems are common in defense applications, where they are employed in phased-array radars, electronic warfare and direction-finding systems. Phased-array radars use hundreds of transmit/receive (TX/RX) modules, each a complete transceiver that together provides rapid electronic beam steering. Electronic warfare and electronic countermeasures employ multiple

receivers to identify and jam threatening emitters. To precisely locate a particular emitter, direction-finding systems use multiple-receiver systems to precisely locate the source of an RF emission. Multiple receivers are also used in geolocation systems, such as Interferometric Synthetic Aperture Radar (InSAR), which can detect the location of events such as earthquakes and floods. They employ several phase-coherent receivers to determine the position of a transmitted or reflected signal.

The issue of phase coherency is even affecting the wireless communications environment in the form of multiple-input, multiple-output (MIMO) technology. A MIMO system combines a “smart” antenna system with multiple elements along with high-speed digital signal processing to dynamically optimize the system’s radiation and reception patterns in response to the signal environment. MIMO uses a technique of transmitting different data on each of the transmitters but all at the same frequency. The result can be significant increases in system efficiency. However, to demodulate the data, the transmitted signals must be coherent.

Testing imperative

Before any of these multireceiver systems is deployed, it must be calibrated and thoroughly evaluated under the signal conditions it is likely to experience in service. This includes exposure to a signal either received directly from an emitter at a specific location or reflected from a target. When the system under test employs only one receiver, a solution for simulating the signal conditions is comparatively simple: A signal generator produces a signal with a single set of amplitude, phase, frequency and time characteristics. The receiver’s response to the signal is then evaluated. However, when testing systems with more than one receiver, the simulator must be able to create and output signals with the varying conditions experienced by each receiver. This is a much more difficult task.

A simulation system designed for testing multireceiver systems must be able to output multiple phase-coherent signals, each one slightly different in its characteristics, and inject them into the RF or IF section of each receiver under test. This requires the use of synthesized signal sources that are tightly controlled and correlated in phase, amplitude, frequency and time in relation to one another.

Multiple signal generators operated non-coherently cannot provide this capability because their characteristics are varying and uncontrolled. For example, several standard signal generators might be used to generate the variants of a transmitted (or reflected) signal. However, because their performance cannot be correlated, the receiver testing will yield inaccurate results. They would manifest themselves in a radar system by positioning the target incorrectly or misinterpreting its velocity.

The answer to accurate signal simulation lies in providing phase coherency among the signal generators used for the simulation, delivering complete control over the phase of each instrument relative to the others in the test system. There has until recently been no simple way to accomplish this with

commercial test equipment. System builders instead rely on field testing or construct test systems themselves with varying results. With the current cost of military field testing at about \$100,000 an hour (using a two-aircraft flyover), the use of this alternative should be relegated to final system demonstration rather than at the design stage.

The alternative solution proposed in this article can accurately reproduce signal conditions in the laboratory or even on the flight line, without resorting to field testing or using a variety of components from different manufacturers (with the designer left to assemble them to produce the simulator). It uses commercial test equipment and can handle any signal within the capabilities of the signal generators on which it is based.

Problem and solution

In an uncontrolled test system using multiple signal generators (see Figure 2), the two local oscillators (LOs) will not be phase-locked together, so the phase of one cannot be aligned with the others as performance drifts over time. In addition, the two separate time bases for each of the instruments' arbitrary waveform generators will also not be phase-locked, which will result in a time

difference in their starting points of up to 20 ns when keyed from the same trigger.

To solve the issue of drift among multiple LOs and provide RF phase coherency, the phase-coherent test system described here uses a single LO that is distributed to multiple signal generators via a power splitter as depicted in Figure 3. The signals are all inherently coherent because they are generated by a single LO. After the LO distribution, each signal generator's modulation chain is employed to produce signals with the desired characteristics.

Coherency must also be established at the baseband level. This is accomplished in the arbitrary waveform generators by driving them with a single external clock. Because both generators now operate from the same clock, they will latch at the same time when externally triggered. This effectively accomplishes complete time alignment and control.

All of the components in the signal generators after the RF signal is split have their own group delay. Consequently, the total delay through each synthesizer is different. This essentially establishes a fixed phase offset between the instruments at a given frequency and amplitude. Once the phase offset has been determined, phase alignment of the

signal generators can be accomplished by offsetting the phase using the I/Q waveforms. A different phase offset can be maintained at any frequency, amplitude and temperature.

The difference in phase between the signal generator outputs will also be affected by amplitude. If the power of one of the outputs is changed by 1 dB, there will be a corresponding change in-phase of 3°. However, if all outputs are changed by the same amount, this phase change will be minimal.

Temperature also affects phase. Every 1°C change in the instrument's temperature will produce a 0.5° change in phase. Once again this is true if only one signal generator's temperature changes. If all instruments' temperatures are changed by the same amount, phase change will be much less.

Phase repeatability is another key performance characteristic. If the phase differences between the two instruments are measured, the output frequency is changed, and the system is returned to its original settings, it is possible that phase will have changed. Fortunately, this is not a problem with this system, and stability can be maintained to better than 0.2°. With this level of repeatability, it is possible to calibrate the system once per day at all frequencies and power levels

and to produce reliable measurements without having to recalibrate each time.

Measurement configuration

The phase-coherent simulation system can be implemented using either Agilent ESG or PSG series vector signal generators, depending on the output frequencies desired. A typical simulation system using the ESG series instruments is shown in Figure 4. The major components include as many as eight signal generators, a 200 MHz-400 MHz external clock to drive the instruments' arbitrary waveform generators, and a "lockbox" that provides the RF splitting function along with the amplification required to drive all of the signal generators.

The ESG signal generator at the top of the stack is the master that delivers the fundamental LO signal to the lockbox, which then distributes the signal to the master as well as the remaining seven "slave" ESG signal generators. Agilent provides an optional module that adds an input and output before the modulators in the signal generators. In this case, one of the signal generator outputs is used to drive the modulation chain of the master ESG. The result is phase coherency in the ESG from 250 MHz to 4 GHz.

Another option is required to configure the baseband generator to be driven by an external clock with a signal between 200 MHz to 400 MHz. The clock operates at four times the sample rate, so a 200 MHz clock delivers a 50 MHz sample rate. The range of sample rates using this option is 50 MHz to 100 MHz. If the same external clock is employed to drive multiple clock inputs, all triggers will be simultaneously latched, providing precise time control. If either the modulator input/output or external baseband generator clock input options are selected, they must be installed on each signal generator in the system.

The same basic configuration is used when the PSG vector signal generators are employed to provide a phase-coherent system with a 20 GHz maximum output frequency. However, the broader frequency range of the PSG requires several lockboxes to be used.

Whether using the ESG or PSG series instruments, a network analyzer and control

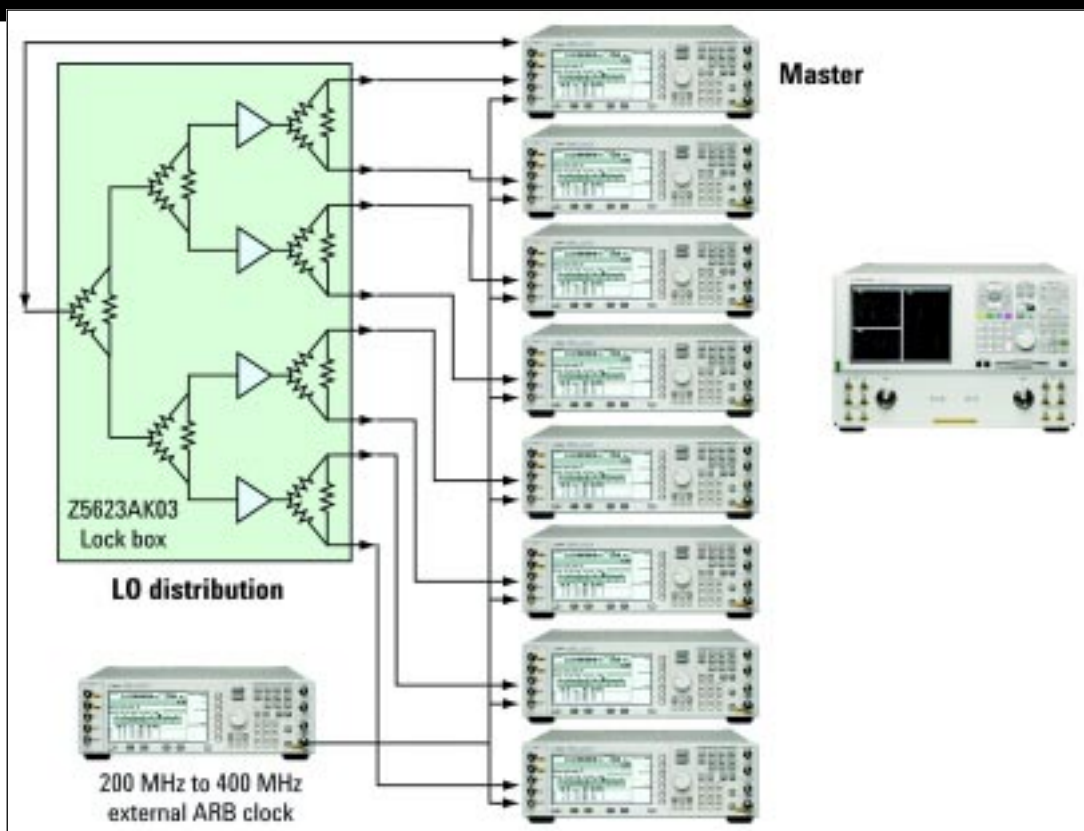

Figure 4. Typical simulation system based on Agilent ESG series vector signal generators.

software are required to phase-align the output signals and ensure absolute phase control between the signal generator output signals. The analyzer measures the difference in phase, and then the software shifts the waveforms to align the signals.

Creating the signal

In addition to the hardware elements of the phase-coherent simulation system, the user must also have software that can create the stimulus signal that will be output by the signal generators. There are many ways to create these signals. The most basic (and perhaps most common) source is actual signal data taken "off the air" that is stored in one of several common file formats. The data can be transferred to simulation tools such as Agilent's Advanced Design System, MATLAB or custom software, which is then downloaded into the system.

Agilent also offers a Windows software application called Signal Studio for pulse building that dramatically simplifies the process of creating complex, single-emitter pulse patterns by eliminating the need for manual math calculation.

Conclusion

Testing of multireceiver systems used in systems such as phased-array radars, communications networks, and synthetic aperture radar has traditionally been difficult and expensive. Field testing, while perhaps necessary for final system verification, is an

expensive method when applied during the design phase.

The phase-coherent simulation system developed by Agilent provides a more repeatable, configurable alternative that can be used in the laboratory or the flight line. It is comprised solely of commercially available equipment and requires only the addition of waveforms used to stimulate the receivers. The system provides the full-phase coherency that is mandatory for testing multireceiver systems, as well as full control over time, phase, amplitude and frequency. **DE**

ABOUT THE AUTHOR

John Hutmacher is global initiative manager in the A/D Business team for the Agilent Technologies Inc., Electronic Products Solutions Group. He graduated from California State University, Chico, with a double B.S. degree in electrical engineering and computer engineering. He worked at the Naval Air Warfare Center for five years while completing his degrees. Since joining Agilent, he has been a product manager and sales development engineer focused on aerospace and defense in the Americas.